



# LAMBERTSON INDUSTRIES

HIGH-QUALITY STAINLESS STEEL

## DISHTABLE SCHEMATICS

WALL MOUNTED

# DISH SLANT RACK SHELVES

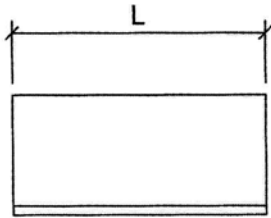
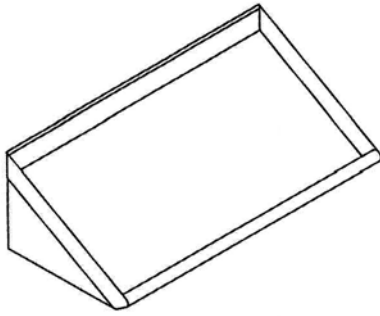

PLAN VIEW

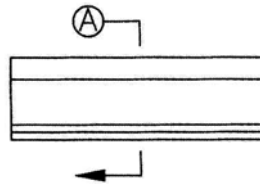

SECTION VIEW

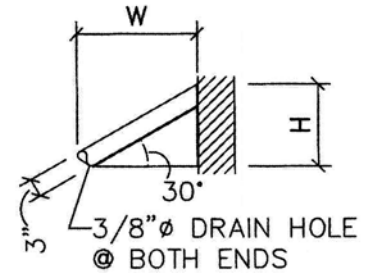

ELEVATION VIEW

MODEL	L	W	H	RACK SIZE	WEIGHT
SWS-1	21"	17"	12-1/8"	16" ROUND	15 LBS.
SWS-2	40"	17"	12-1/8"	16" ROUND	25 LBS.
SWS-3	57"	17"	12-1/8"	16" ROUND	35 LBS.
SWS-4	21"	19-7/8"	13-7/8"	20" X 20"	20 LBS.
SWS-5	42"	19-7/8"	13-7/8"	20" X 20"	40 LBS.
SWS-6	63"	19-7/8"	13-7/8"	20" X 20"	50 LBS.



### NOTES

- ▶ SHELF — 16 GAUGE TYPE 304 STAINLESS STEEL WITH INTEGRALLY FORMED SANITARY ROLL AT FRONT AND TURNED UP AT REAR AND ENDS.
- ▶ CORRUGATED DRY ZONE SURFACE (FLAT SURFACE TO BE SPECIFIED BY CUSTOMER)
- ▶ WALL MOUNTING BRACKETS — 16 GAUGE TYPE 304 STAINLESS STEEL WITH FLANGE PRE-PUNCHED AT FACTORY FOR MOUNTING TO WALL. BRACKETS ARE SHIPPED LOOSE FROM SHELF AND ARE TO BE MOUNTED IN FIELD BY OTHERS.

LAMBERTSON INDUSTRIES • 1335 ALEXANDRIA COURT • SPARKS, NV 89434

PHONE: 775-857-1100 • FAX: 775-857-3289 • TOLL-FREE: 800-548-3324

