

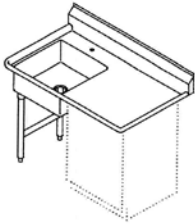

# LAMBERTSON INDUSTRIES

HIGH-QUALITY STAINLESS STEEL  
DISHTABLE SCHEMATICS



## SINK ON LEFT UNDERCOUNTER DISHTABLES

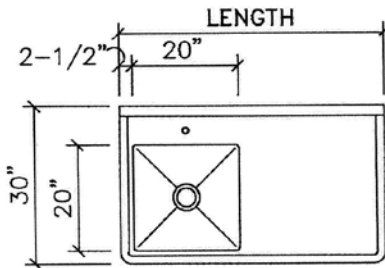

PLAN VIEW

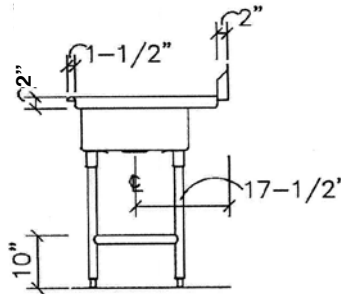

SECTION VIEW

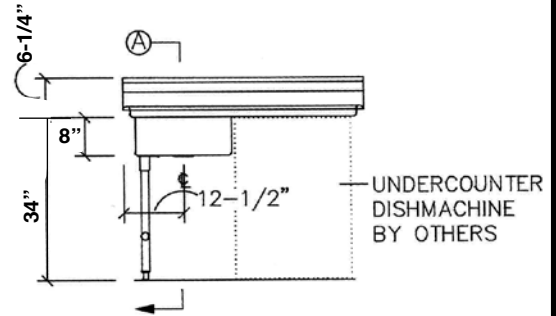

ELEVATION VIEW

MODEL	LENGTH	WEIGHT
DTU-4-LR	48"	45 LBS.
DTU-5-LR	60"	55 LBS.



**CORRUGATED  
DRY ZONE™**

### NOTES

- ▶ TOP — 16 GAUGE TYPE 304 STAINLESS STEEL WITH INTEGRALLY FORMED BACKSPLASH AND SANITARY ROLL ON 3 SIDES.
- ▶ CORRUGATED DRY ZONE SURFACE (FLAT SURFACE TO BE SPECIFIED BY CUSTOMER)
- ▶ SINK — 20" X 20" X 8" DEEP 16 GAUGE STAINLESS STEEL WITH 3-1/2" DIE STAMPED CENTER DRAIN OPENING. SINK IS INTEGRALLY WELDED TO TOP.
- ▶ LEGS — 1-5/8" O.D. 16 GAUGE GALVANIZED TUBING WITH STAINLESS STEEL LEG GUSSETS AND ADJUSTABLE SANITARY BULLET TYPE FEET.
- ▶ CROSSBRACING — 1-5/8" O.D. GALVANIZED TUBING FULLY WELDED TO LEGS. STAINLESS STEEL LEGS AND FEET ARE AVAILABLE AT ADDITIONAL COST.
- ▶ BASKET DRAIN FITTING IS SUPPLIED BY LAMBERTSON.

LAMBERTSON INDUSTRIES • 1335 ALEXANDRIA COURT • SPARKS, NV 89434

PHONE: 775-857-1100 • FAX: 775-857-3289 • TOLL-FREE: 800-548-3324

