

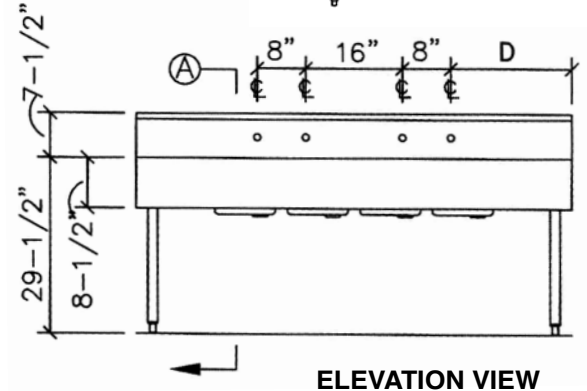

LAMBERTSON INDUSTRIES

HIGH-QUALITY STAINLESS STEEL
BARSINKS SCHEMATICS

FOUR TUB STAR BRIGHT UNDERBAR SINKS

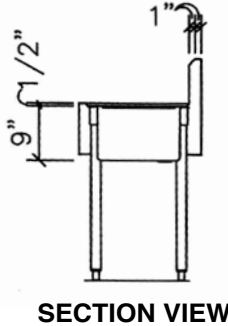
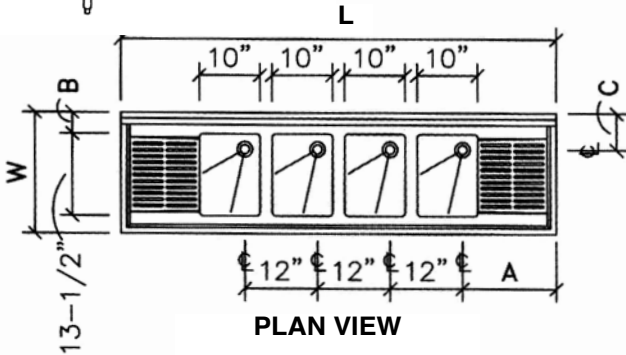
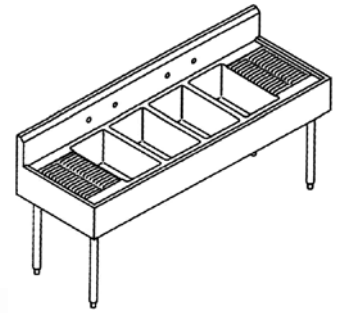
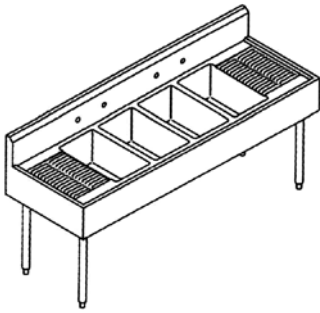

MODEL	L	W	A	B	C	D	WEIGHT
4SL-6-2D12	72"	20"	15-1/2"	3-1/2"	6"	20"	70 LBS.
4SL-6-2D12-4	72"	24"	15-1/2"	5-1/2"	8"	20"	80 LBS.
4SL-7-2D18	84"	20"	21-1/2"	3-1/2"	6"	26"	80 LBS.
4SL-7-2D18-4	84"	24"	21-1/2"	5-1/2"	8"	26"	80 LBS.
4SL-8-2D24	96"	20"	27-1/2"	3-1/2"	6"	32"	90 LBS.
4SL-8-2D24-4	96"	24"	27-1/2"	5-1/2"	8"	32"	100 LBS.
4SL-9-2D30	108"	20"	33-1/2"	3-1/2"	6"	38"	100 LBS.
4SL-9-2D30-4	108"	24"	33-1/2"	5-1/2"	8"	38"	110 LBS.



NOTES

- ▶ TOP — 16 GAUGE TYPE 304 STAINLESS STEEL WITH INTEGRALLY FORMED BACKSPASH AND MARINE EDGE AT THREE SIDES.
- ▶ CORRUGATED DRY ZONE SURFACE (FLAT SURFACE TO BE SPECIFIED BY CUSTOMER)
- ▶ SINK — 16 GAUGE TYPE 304 STAINLESS STEEL ALL WELDED CONSTRUCTION. ALL VERTICAL AND HORIZONTAL CORNERS WITH 5/8" RADIUS COVE. BOTTOM OF TUBS ARE PITCHED TOWARD DIE STAMPED CENTER DRAIN OPENING. TUBS ARE INTEGRALLY WELDED TO TOP.
- ▶ LEGS — 1-5/8" 16 GAUGE GALVANIZED TUBING WITH STAINLESS STEEL LEG GUSSETS AND ADJUSTABLE SANITARY BULLET TYPE FEET.
- ▶ CUSTOM SIZES AND CONFIGURATIONS AVAILABLE.

LAMBERTSON INDUSTRIES • 1335 ALEXANDRIA COURT • SPARKS, NV 89434

PHONE: 775-857-1100 • FAX: 775-857-3289 • TOLL-FREE: 800-548-3324

