



LAMBERTSON INDUSTRIES

HIGH-QUALITY STAINLESS STEEL

BARSINKS SCHEMATICS

STAR BRIGHT UNDERBAR BLENDER STATION WITH DUMP SINK

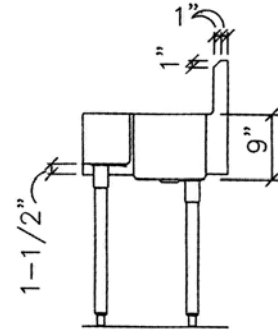
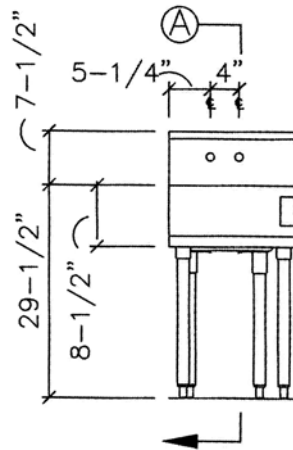
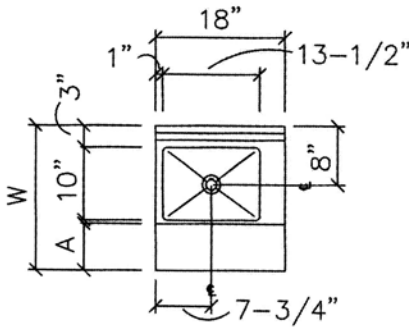
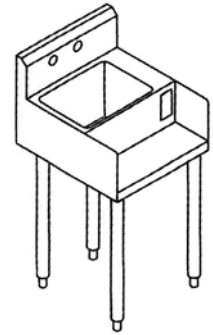
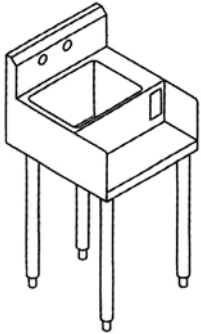

MODEL	W	A	WEIGHT
BSDS-18-S	20	6-1/2"	40 LBS.
BSDS-18-S-4	24	10-1/2"	45 LBS.

NOTES

- ▶ TOP — 16 GAUGE TYPE 304 STAINLESS STEEL WITH INTEGRALLY FORMED BACKSPLASH AND BLENDER SHELF. REAR PANEL OF BLENDER SHELF WITH CUT-OUT FOR DUPLEX ELECTRICAL OUTLET. (J-BOX WELDED IN BY LAMBERTSON.
- SINK — 16 GAUGE TYPE 304 STAINLESS STEEL ALL WELDED CONSTRUCTION. ALL VERTICAL AND HORIZONTAL CORNERS WITH 5/8" COVE RADIUS. BOTTOM OF TUB IS PITCHED TOWARD DIE STAMPED CENTER DRAIN OPENING. TUB IS INTEGRALLY WELDED TO TOP.
- ▶ LEGS — 1-5/8" O.D. 16 GAUGE GALVANIZED STEEL TUBING WITH STAINLESS STEEL LEG GUSSETS AND ADJUSTABLE SANITARY BULLET TYPE FEET.
- ▶ CUSTOM SIZES AND CONFIGURATIONS AVAILABLE.

LAMBERTSON INDUSTRIES • 1335 ALEXANDRIA COURT • SPARKS, NV 89434

PHONE: 775-857-1100 • FAX: 775-857-3289 • TOLL-FREE: 800-548-3324

