

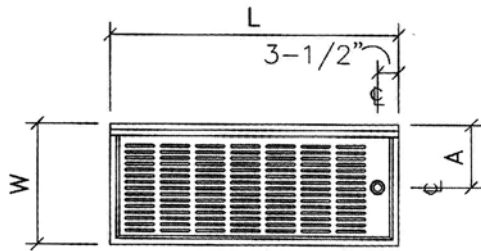

# LAMBERTSON INDUSTRIES

HIGH-QUALITY STAINLESS STEEL  
BARSINKS SCHEMATICS

## STAR BRIGHT UNDERBAR DRAIN BOARD W/RIGHT DRAIN

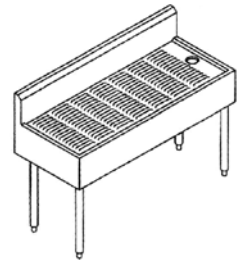
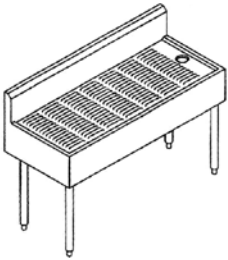

PLAN VIEW

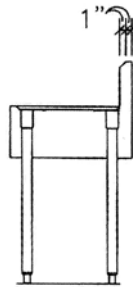

SECTION VIEW

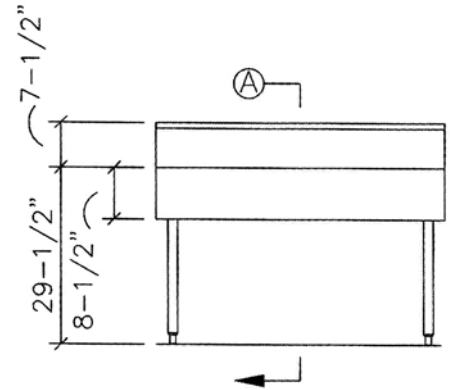

ELEVATION VIEW

MODEL	L	W	A	WEIGHT
DR-3-R	36"	20"	8-1/4"	35 LBS.
DR-3-R-4	36"	24"	10-1/4"	40 LBS.
DR-4-R	48"	20"	8-1/4"	45 LBS.
DR-4-R-4	48"	24"	10-1/4"	50 LBS.
DR-5-R	60"	20"	8-1/4"	55 LBS.
DR-5-R-4	60"	24"	10-1/4"	60 LBS.
DR-6-R	72"	20"	8-1/4"	65 LBS.
DR-6-R-4	72"	24"	10-1/4"	70 LBS.

### NOTES

- ▶ TOP — 16 GAUGE TYPE 304 STAINLESS STEEL WITH INTAGRALLY FORMED BACKSPLASH, MARINE EDGE AT THREE SIDES AND RAISED DIMPLES ON DRAINBOARD. DRAINBOARD HAS DIE STAMPED DRAIN OPENING AT END.
- ▶ LEGS — 1-5/8" O.D. 16 GAUGE GALVANIZED STEEL TUBING WITH STAINLESS STEEL LEG GUSSETS AND ADJUSTABLE SANITARY BULLET TYPE FEET.
- ▶ CUSTOM SIZES AND CONFIGURATIONS AVAILABLE.

LAMBERTSON INDUSTRIES • 1335 ALEXANDRIA COURT • SPARKS, NV 89434

PHONE: 775-857-1100 • FAX: 775-857-3289 • TOLL-FREE: 800-548-3324

