



# LAMBERTSON INDUSTRIES

HIGH-QUALITY STAINLESS STEEL

## BARSINKS SCHEMATICS

# TWO TUB STAR BRIGHT UNDERBAR COCKTAIL STATION

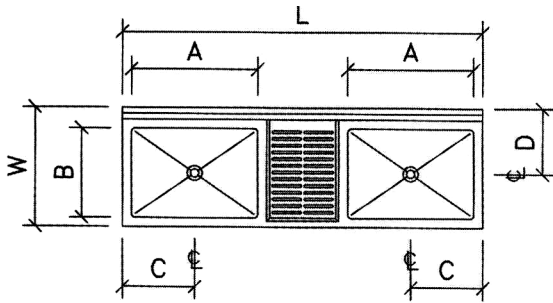
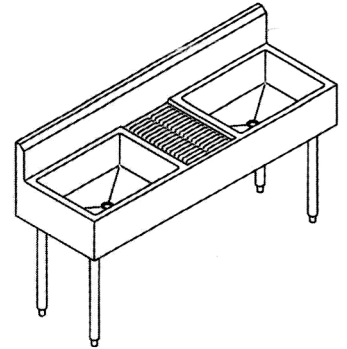
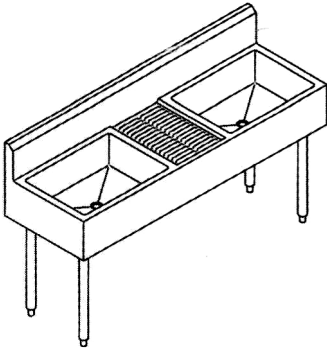

PLAN VIEW

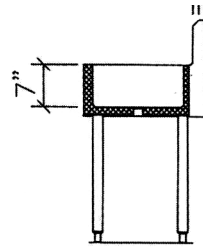

SECTION VIEW

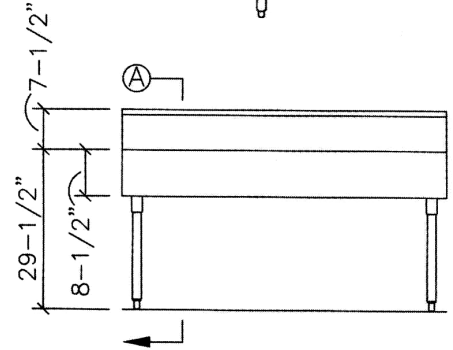

ELEVATION VIEW

MODEL	L	W	A	B	C	D	ICE CAPACITY	WEIGHT
2-CS-24-CD12	60"	20"	21"	15"	12"	11"	60 LBS.	95 LBS.
2-CS-24-CD12-4	60"	24"	21"	20"	12"	13"	120 LBS.	110 LBS.
2-CS-30-CD12	72"	20"	27"	15"	15"	11"	114 LBS.	115 LBS.
2-CS-30-CD12-4	72"	24"	27"	20"	15"	13"	154 LBS.	130 LBS.
2-CS-36-CD12	72"	20"	21"	15"	18"	11"	90 LBS.	105 LBS.
2-CS-36-CD12-4	72"	24"	21"	20"	18"	13"	120 LBS.	120 LBS.

### NOTES

- ▶ TOP — 16 GAUGE TYPE 304 STAINLESS STEEL WITH INTEGRALLY FORMED BACKSPLASH.
- ▶ ICE BIN — 16 GAUGE TYPE 304 STAINLESS STEEL ALL WELDED TUB WITH ALL VERTICAL AND HORIZONTAL CORNERS WITH 5/8" RADIUS COVE. BOTTOM OF TUB IS PITCHED TOWARD DIE STAMPED CENTER DRAIN OPENING. TUB IS SURROUNDED BY 1" FIBERGLASS INSULATION WITH GALVANIZED SHELL AT BOTTOM AND REAR.
- ▶ LEGS — 1-5/8" O.D. TYPE 304 STAINLESS STEEL TUBING WITH STAINLESS STEEL LEG GUSSETS AND ADJUSTABLE SANITARY
- ▶ CUSTOM SIZES AND CONFIGURATIONS AVAILABLE.

1335 ALEXANDRIA COURT  
SPARKS, NV 89434

LAMBERTSON INDUSTRIES, INC.  
PHONE 775 · 857 · 1100  
TOLL-FREE 800 · 548 · 3324  
FAX 775 · 857 · 3289

WWW.LAMBERTSON.COM  
SALES@LAMBERTSON.COM

